



www.italconveyors.com

italconveyors
CONVEYOR BELTS



NASTRI TRASPORTATORI RETTILINEI E CURVI

Applicazioni:

- CONFEZIONAMENTO
- TRASPORTO PRODOTTI INDUSTRIALI
- TRASPORTO PRODOTTI ALIMENTARI
- STAMPAGGIO PLASTICA

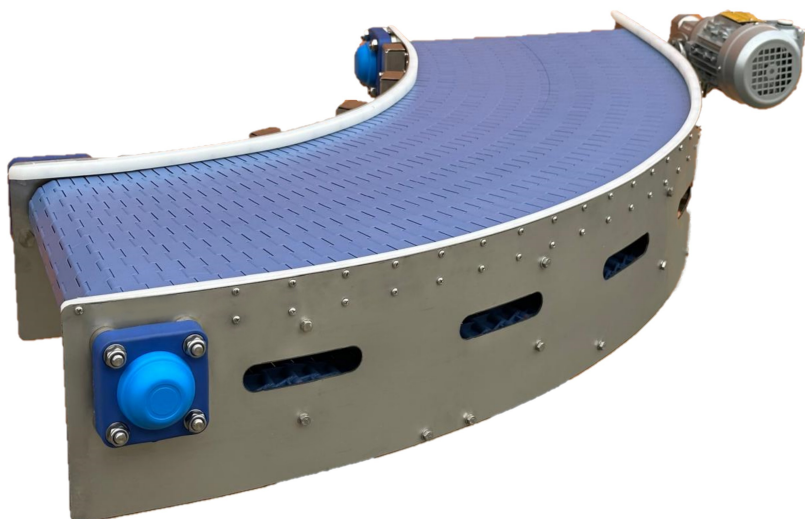



TIPOLOGIE PRINCIPALI DI TRASPORTATORI

n.1 - ORIZZONTALE

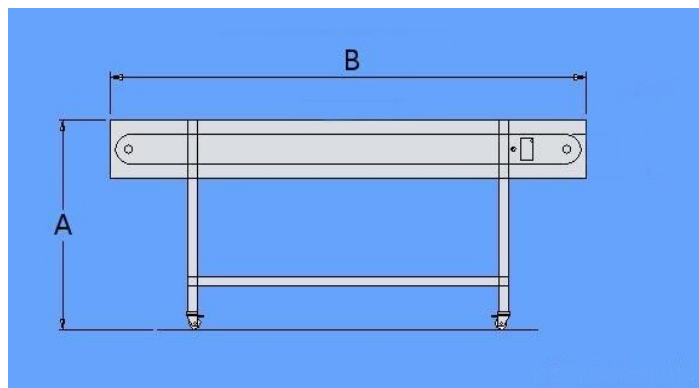

n.2 - INCLINATO IN SALITA
n.3 - INCLINATO IN DISCESA

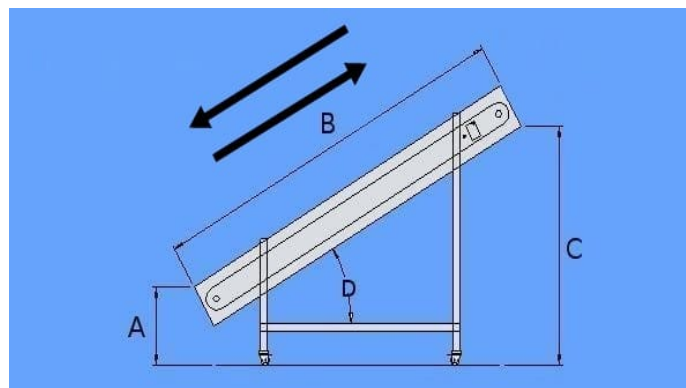

n.4 - INCLINATO IN SALITA CON BASE PIANA
n.5 - INCLINATO IN DISCESA CON BASE PIANA

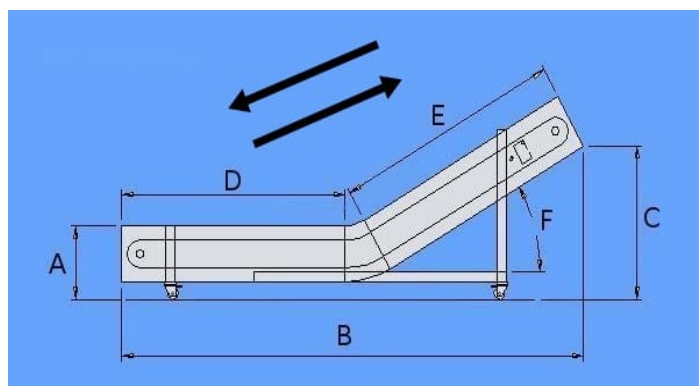

n.6 - INCLINATO IN DISCESA CON BASE PIANA
n.7 - INCLINATO IN SALITA CON BASE PIANA

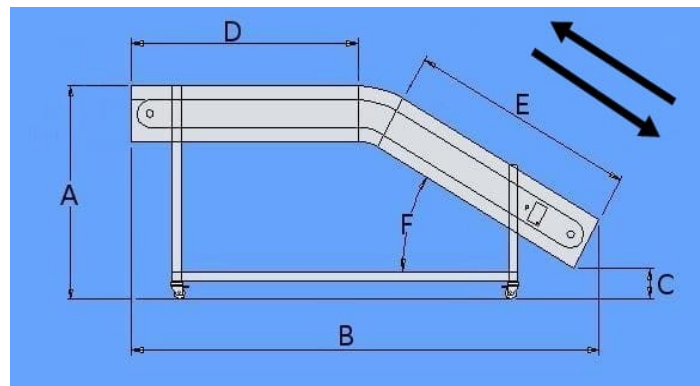

n.8 - COLLO DI CIGNO IN SALITA
n.9 - COLLO DI CIGNO IN DISCESA

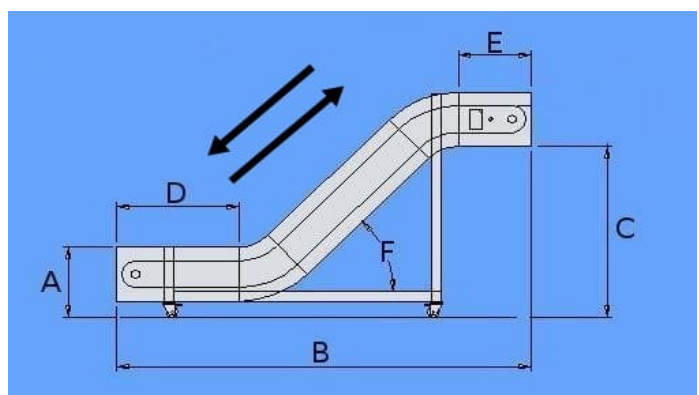

**ulteriori configurazioni sono
disponibili su richiesta**

DATI PER RICHIEDERE UN'OFFERTA

Azienda Tel.
Indirizzo
Sig./Sig.ra..... tel./cell.
E-mail

- Indicare numero e tipologia di trasportatore.....
- Indicare le misure:
 - A.....
 - B.....
 - C.....
 - D.....
 - E.....
 - F.....
- Largh.utile del nastro mm.....
- Materiale struttura: Acciaio Inox - Acciaio verniciato - Alluminio.....
- Struttura su ruote - Piedini regolabili.....
Prodotto da trasportare: sfuso - singoli pezzi.....
- Peso totale sul nastro in kg.....
- Velocità del nastro mt/min.....
- Funzionamento: continuo - start e stop.....
- Motorizzazione: no - si - tipo di motoriduttore richiesto.....
- Quadro elettrico: si - no.....
- Indicare come il prodotto viene caricato sul nastro.....
- Indicare dove viene scaricato il prodotto.....
- Sponde laterali: si - no - altezza.....
- Tramoggia carico: si - no.....
- Schema/schizzo per trasportatore a richiesta nella pagina seguente



SCHEMA/SCHIZZO DEL TRASPORTATORE SU RICHIESTA

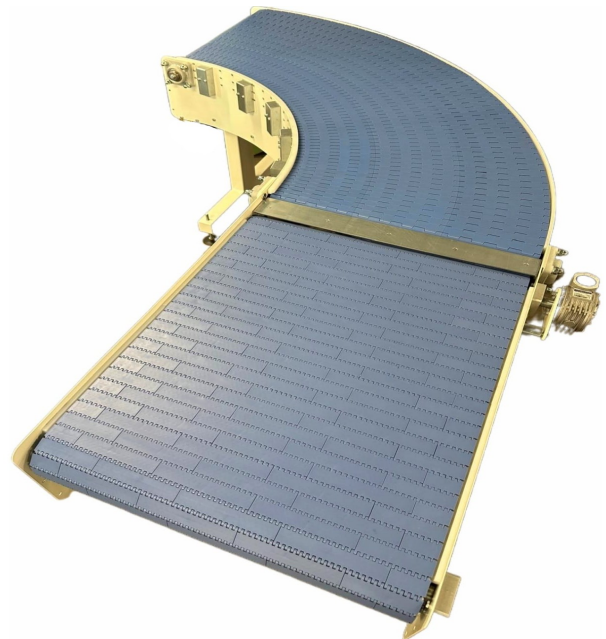

Per ogni informazione tecnica o commerciale, contattateci

Contatti



+39 059364813



info@italconveyors.com
www.italconveyors.com



Italconveyors S.r.l.
Via Gandhi, 9/A 41122 Modena, Italia

TEL +39 059 364813
FAX +39 059 8375130

P.I. - C.F 03082420369